

DISCLAIMER
 THIS MAP WAS PREPARED FOR LOCAL PROPERTY ASSESSMENT PURPOSES ONLY AND THE PARCELS SHOWN HEREON MAY NOT COMPLY WITH STATE AND LOCAL SUBDIVISION ORDINANCES, AND NO LIABILITY IS ASSUMED FOR THE USE OF THE INFORMATION SHOWN HEREON. R & T CODE SEC. 327, 408.3, ETC.

N1/2 SEC.29, T.20S., R.27E., M.D.B.&M.

Tax Area Codes 215-35
 139-006

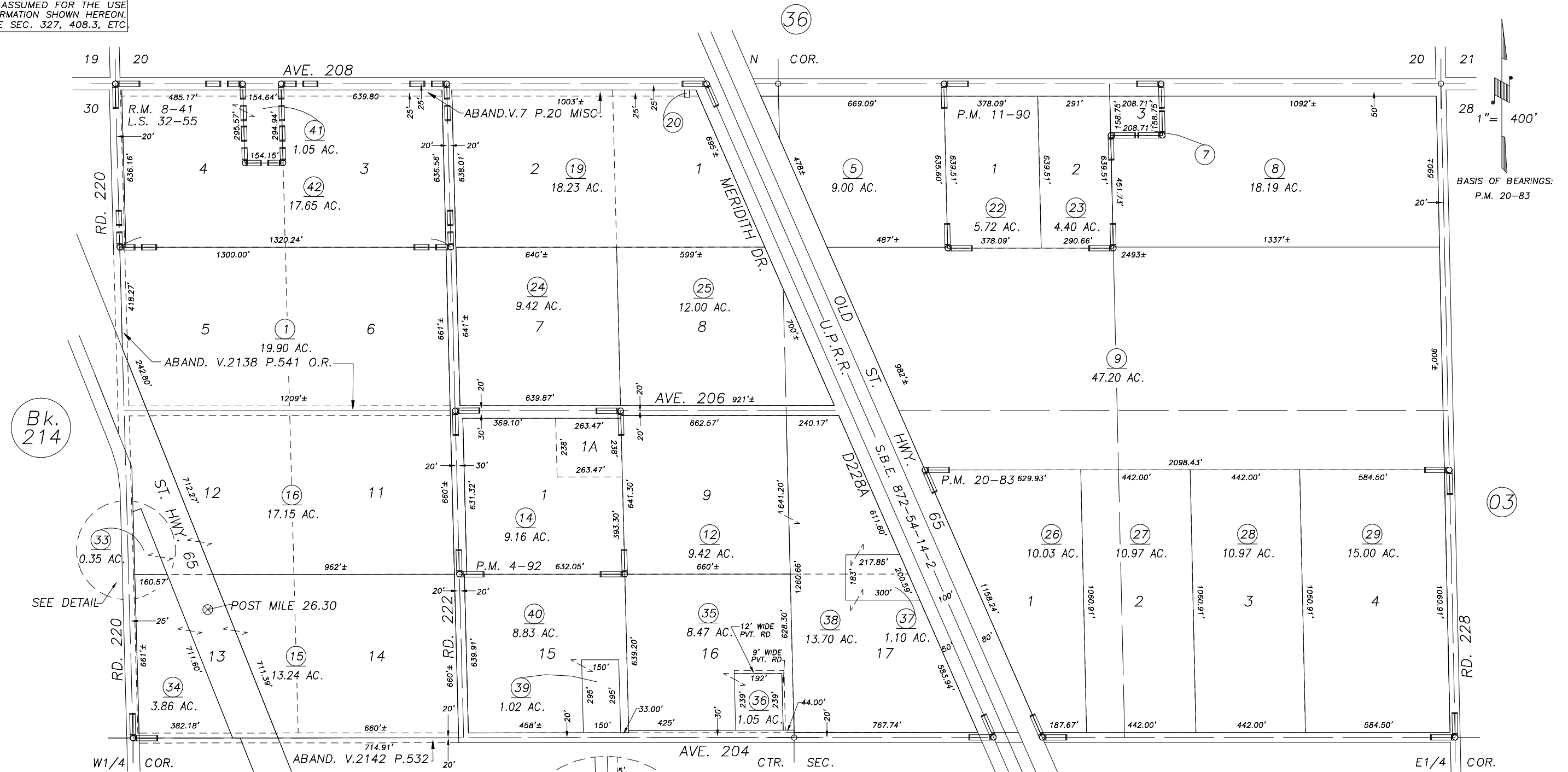

Bk. 214

SEE DETAIL

NEW YORK TRACT, R.M. 8-41
 PARCEL MAP NO. 392, P.M. 4-92
 PARCEL MAP NO. 1089, P.M. 11-90
 PARCEL MAP NO. 1982, P.M. 20-83
 RECORD OF SURVEY, L.S. 17-85 (HWY 65)
 RECORD OF SURVEY, L.S. 32-55

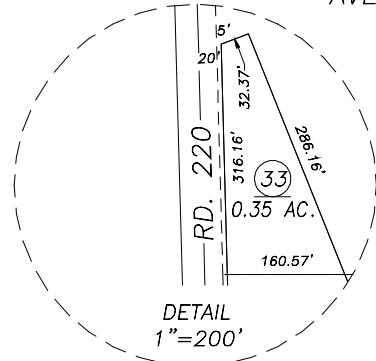

VICINITY OF LINDSAY
 ASSESSOR'S MAPS BK.215 , PG.35
 COUNTY OF TULARE, CALIFORNIA, U.S.A.

NOTE: Assessor's Parcel Numbers Shown in Circles
 Assessor's Block Numbers Shown in Ellipses

2014-0021672	6/6/2017	GL
REVISION	DATE	TECH